

100 90 80 70 60 50 40 30 20 10 C.R.L. 10 20 30 40 50 60 70 80 90 100

AREA
S.F.
EXC. EMB.

VOLUME
C.Y.
EXC. EMB.

35
+
00

35
+
00

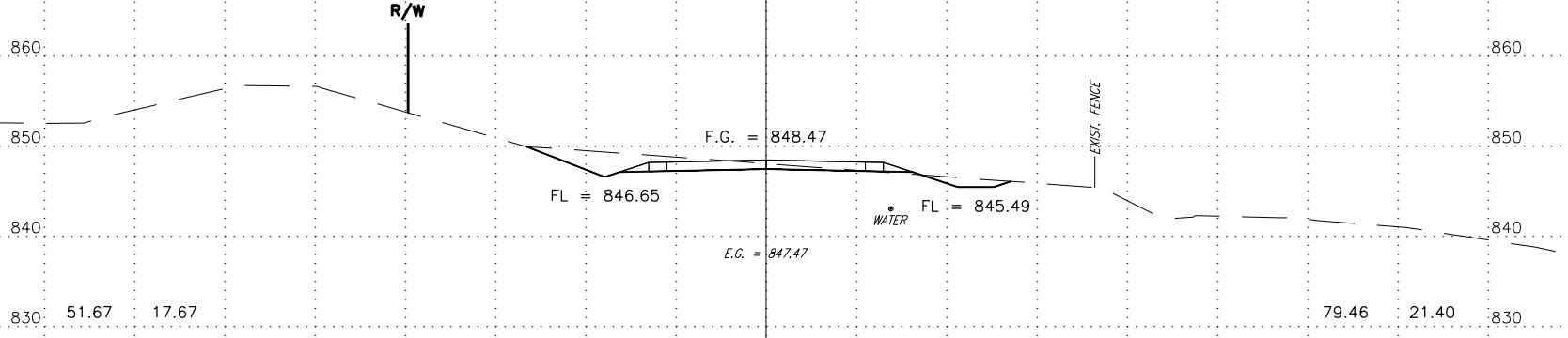

34
+
50

34
+
50

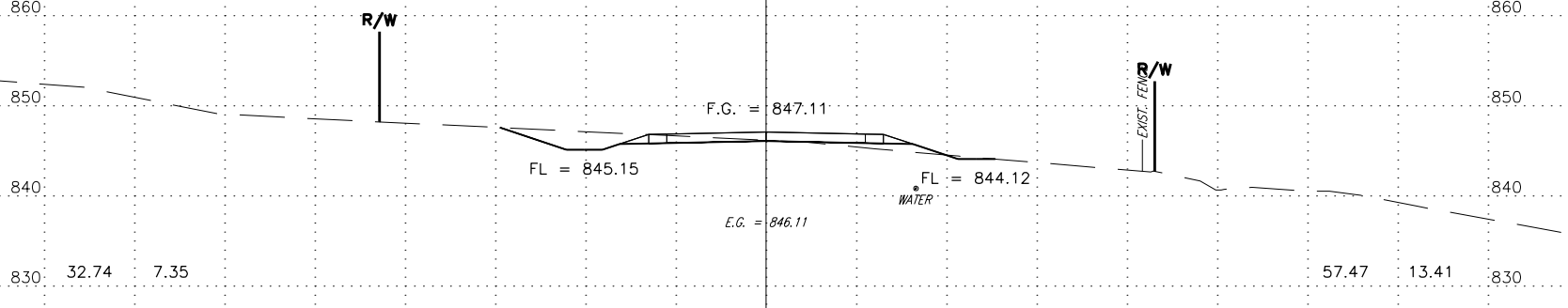

34
+
00

34
+
00

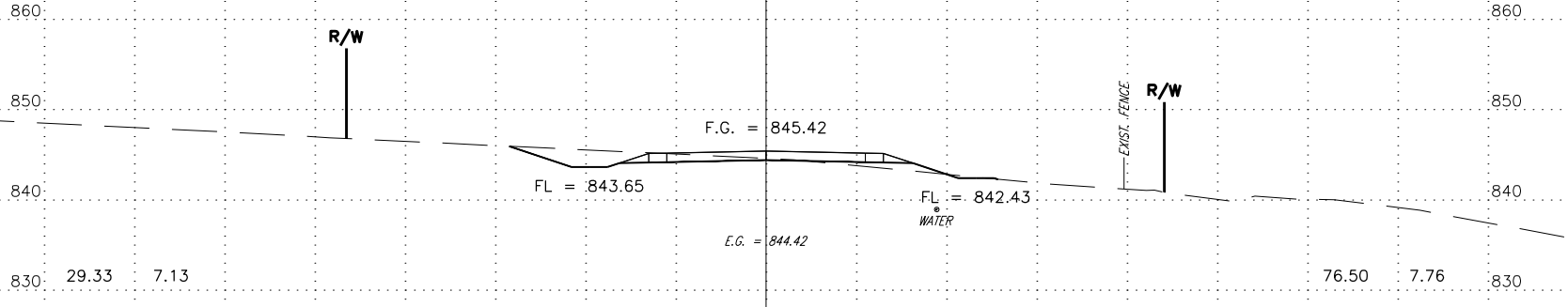

33
+
50

33
+
50

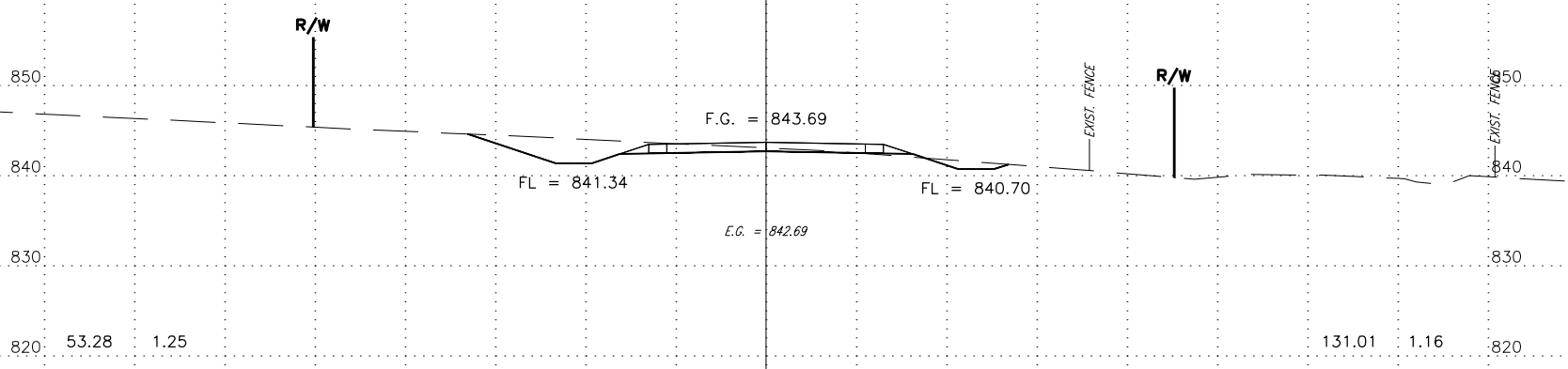

33
+
00

33
+
00

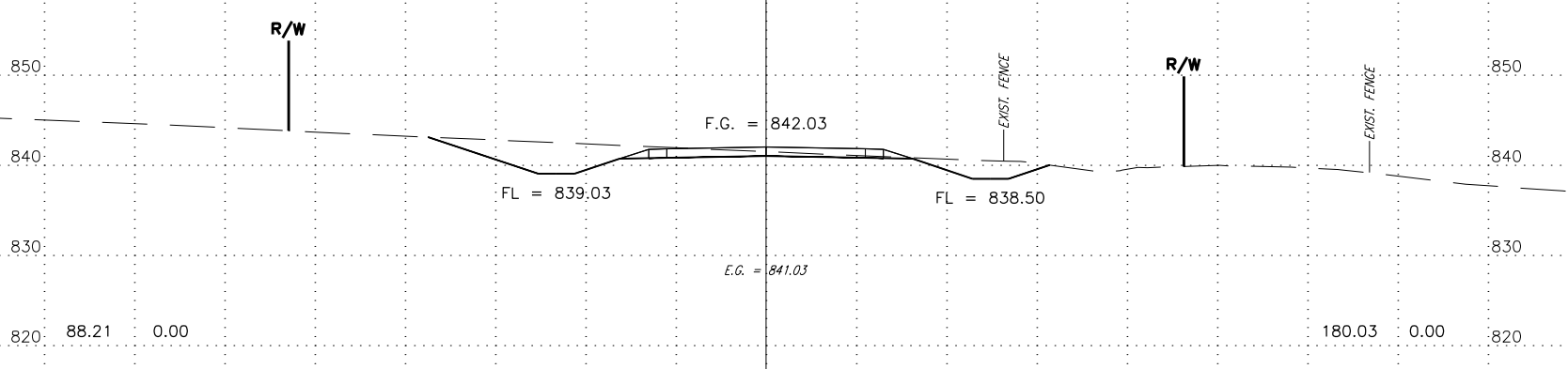

ALL UTILITY LOCATIONS & DEPTHS ARE APPROXIMATE.

0 5' 10' 20'
FILE: 13228 WALNUT CREEK LWC - BASEMAP.DWG
DATE: 4/13/17
STATE JOB PIECE NO. 28448(04) SHEET NO. X012

100 90 80 70 60 50 40 30 20 10 C.R.L. 10 20 30 40 50 60 70 80 90 100